

The Transmitter

Keeping in touch with FRVA friends and family through amateur radio

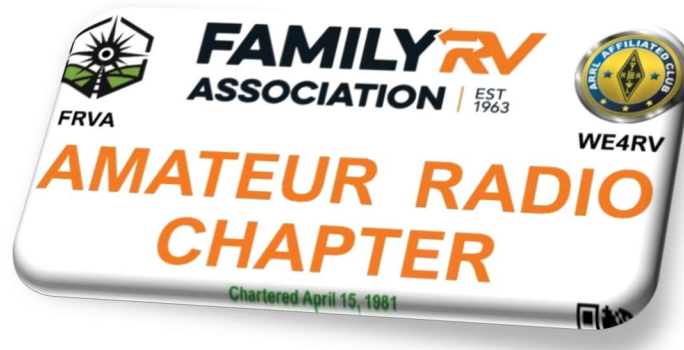

April 2025

Volume 25 Issue 2

Table of Contents

Chapter Information	2
President's Corner	3
Internet Safety Information	4
Vice President's Report	6
New Chapter Banner & Badge	7
Save the Dates	8
Vintage Ham Radio Crossword Puzzle	9
National Director's Report	10
Blast from the Past	10
Secretary Report/General Meeting Minutes	11
Board Meeting	12
Treasurers/Budget Report	13
Website Chairperson	14
Quarterly Quote	15
Membership Report	16
Member Contribution: Newfoundland Hammin' Trip N5DSW	17
Member Contribution: SDRPLAY Panadapter WB5MRG	21
Member Contribution: Wonderlust Dreams by LJRB	26
Rally Registration Form	27

Note: An Index of Transmitter Articles is now available. To access past articles, Go to the following link: [Transmitter Article Index](#)

Chapter Information

President: Doug Barko NZ2W

nz2w@nz2w.com

Vice President: Dennis Dugan WA0YPC

wa0ypc@gmail.com

Treasurer: Jana Bechtoldt N9PBF

bechtjl@gmail.com

Secretary: Karen Hamilton, WB5UFM

gmommykaren@gmail.com

National Director: George Raney KG5LRB

kg5lrb@newmexico.com

Committee Chairpersons:

Nominations: Dave Rathke WB4OHV

wb4ohv@yahoo.com

Standing Rules: Skip Kazmarek K4EAK

skazmarek@mindspring.com

Managers:

HF Communications: Dave Rathke WB4OHV

wb4ohv@yahoo.com

Membership: Jana Bechtoldt N9PBF

bechtjl@gmail.com

The Transmitter is produced by:

Edited by: Lana Blackstock

lanajblk@att.net

Mailed by: Dave Rathke WB4OHV

wb4ohv@yahoo.com



FRVA ARC Net Times

Time	Freq	Mode
12:15 PM ET	14.30750	USB

Our net is made up of amateurs who own RVs and are members of the Family RV Association (FRVA). The purpose of this net is to pass traffic among our members, keep in touch with our members as they travel, and promote mobile amateur radio in general. You do not have to be a member of FRVA, the Amateur Radio Chapter, or own an RV to join this net. Any properly licensed amateur radio operator is invited to join our net.

EchoLink Net Tuesday 9 PM ET

Node *FMCA-ARC*

Sponsors: AA4GH and WB9FHL

Node info: [FRVA-ARC Net Info](#)

Tech Net Thursday 8 PM ET

Sponsors: WB5VQW & WB5MRG

Link: [FRVA-ARC TechNet](#)

President's Corner 1Q25

By Doug Barko, NZ3W

President's Report April 15, 2025

I am pleased that the 2025 Tax Season is completed today. My AARP Team completed a record 250 plus returns this season. So, other than final statistical reports my work is completed for this year.

In the midst of Tax Season, Sharon and I took a break and attended the Spring Rally in Elko, Georgia. It was a great Rally thanks to the hard work of Janet and Dennis Dugan. Given Sharon's injuries from a serious fall last September, Janet and Dennis carried most of the load for hosting the Rally. A

highlight for me was getting to play DJ for the Sock-Hop. No one was able to stump the DJ with requests thanks to the use of Apple Music.

On a more serious note, the General Meeting of the membership took action at the Rally to resolve an issue which has been before the Executive Committee since the FRVA (FMCA) doubled the membership fees last fall.

Members had requested clarification as to whether or not they could be a member of the Amateur Radio Chapter if they did not pay National Dues. After much research and deliberation, the Executive Committee recommended that it was not possible to be a member of the ARC if one was not a member in good standing of the National Organization. Both our by-laws and the National by-laws state one must be a member of the FRVA (FMCA) to be a member of the Chapter. If the Chapter did not enforce this rule, we could lose our Charter and thus our access to FRVA benefits including insurance. To replace the insurance coverage, we receive by being related to the FRVA (FMCA) would be financially impossible.

Obviously, this means we may lose some members. However, if you are no longer a member of the ARC you may continue to participate in nets and in rallies. The only caveat is that you could not vote at meetings, you could not hold an office and you would not be eligible for prizes at Rallies.

One additional action which the general meeting enacted is that we will attempt to make future membership meetings hybrid, both in person and on the web. Obviously, this is subject to our working out the technological issues.

73 to all, and hoping to communicate with all of you down the road...





*FMCA is now Family RV Association —
same great RV community, bold new direction!*

Important Internet Safety Information

Family RV Association Chapter Officers,

It has been requested that we provide information on how to stay safe when using the internet. In this digital age, the internet has become an integral part of our daily lives, connecting us globally, providing vast information, and offering endless opportunities. However, along with these benefits come potential risks and threats that can compromise our privacy, security, and well-being.

We are providing essential tips and best practices to safeguard your digital presence and maintain a safe online experience.

How to Protect Yourself from Phishing Scams

Be Skeptical: Always be cautious when receiving unsolicited emails or messages, especially if they create a sense of urgency or demand immediate action.

Verify the Source: Before clicking on any links or providing sensitive information, verify the sender's email address or phone number and cross-check it with official sources.

Avoid Clicking Suspicious Links: Hover your mouse over links to see the actual URL before clicking. If the link looks suspicious or doesn't match the purported sender, avoid clicking it.

Use Multi-Factor Authentication (MFA): Enable MFA whenever possible, as it provides an extra layer of security for your online accounts.

Keep Software Updated: Keep your operating system, web browsers, and antivirus software up to date to minimize vulnerabilities.

Educate Yourself: Stay informed about the latest phishing techniques and trends to recognize potential scams more effectively.

Report Suspected Phishing: If you encounter a phishing attempt, report it to the relevant organization or authority to help prevent others from falling victim.

Protecting Against Malware

Keep Software Updated: Regularly update operating systems, software, and applications to patch known vulnerabilities.

Use Antivirus and Security Software: Install reputable antivirus and security software to detect and prevent malware infections.

Exercise Caution Online: Be cautious when clicking on links, downloading files, or opening attachments from unknown or suspicious sources.

Enable Firewall Protection: Enable firewalls on your devices and networks to block unauthorized access and incoming threats.

Practice Safe Email Habits: Avoid opening emails from unknown sources or clicking on suspicious links or attachments.

Backup Data Regularly: Regularly back up important data to external storage or cloud services to mitigate the impact of a ransomware attack.



Vice President's Report 1Q25

By Dennis Dugan, WA0YPC



The first quarter of 2025 has been busy. We first traveled to Orlando, FL and attended HamCation at the Central Florida Fairgrounds. We had a good turnout of our FRVA-ARC members with about 15 coaches present. There are always lots of vendors to find that special radio item that you didn't realize you really needed! We also had our great potluck dinner with the RVRN and WBCCI groups. Overall attendance and the number of RV's were up for HamCation.

Next was the FRVA's 110th International Convention in Perry, GA in March where several of our FRVA-ARC members were in attendance. We set up an Amateur Radio Chapter booth at the Chapter Fair and a second booth at the "Walk the Plank" Parade displaying our new ARC Banner to promote our chapter and gain new members. We had success with about 10 new members signing up! Thanks to John (WB9FHL) & Jana (N9PBF) Bechtoldt for making the arrangements and providing handouts. We enjoyed the wonderful fireworks provided by the FRVA later that evening. Weather was great except for the 2" of rain on the night before leaving. A few got stuck in the mud, but all our members got out without incident.

At the completion of the FRVA rally we moved to Twin Oaks RV Park in Elko, GA for our FRVA-ARC rally the following week. This was a short drive of only 8 miles, so we didn't even hook up the toad for the move. We had 15 coaches with 28 members in attendance. There were many activities going on including an aviation museum tour, POTA activity, Ladies crafts and quilt shop hopping and some training on D-Star, DMR and hotspot setup. Lots of food including the World Famous Dave's Pancakes & Sausage and Yoder's Deitsch Haus. I believe everyone had a great time!

In my last report I said I was returning to my hobby of woodworking, but I have only completed and installed our laundry room cabinets. Time was just too short to get started on my desk for the Ham Radio setup. Well, I guess there's always another day to make that sawdust fly!

The transition from the FMCA to the FRVA on our website has continued. Most of what is visible to the public has been completed including a new Membership Application Form. Now all the behind scenes work still needs to be completed. If you haven't seen the website in the last couple of months, you should definitely take a look!

[FRVA Website](#)

Our Facebook site has been updated with the new logos. Since the site is a private group you will need to click on the following link to request access: [FRVA ARC Facebook Site](#) If you already have access, it's worth taking a look and encourage you to post or comment. We currently have 98 members with access.

With the name change, we now have new chapter banners to display at our rallies and new name badges are available to purchase. More information and pictures of the banners and name badges appear later in this Transmitter.

The 2025 fall rally has been set! It is in Paducah, KY and thanks to John (WB9FHL) & Jana (N9PBF) Bechtoldt and Olen (W4EZR) & Margie (KE4YWO) Persons for volunteering to Co-Host this Rally. The "Save the Date" flyer and "Registration Form" for this rally appear at the end of this transmitter and are available online at [FRVA Website](#). Get signed up and make your camping reservations!

Safe journeys and hope to see you at one of our Rallies!
73's to everyone! - Dennis (WA0YPC)

Our New Chapter Banner



We have these in 5' x 3' and 4' x 2' sizes

Our New Chapter Name Badge

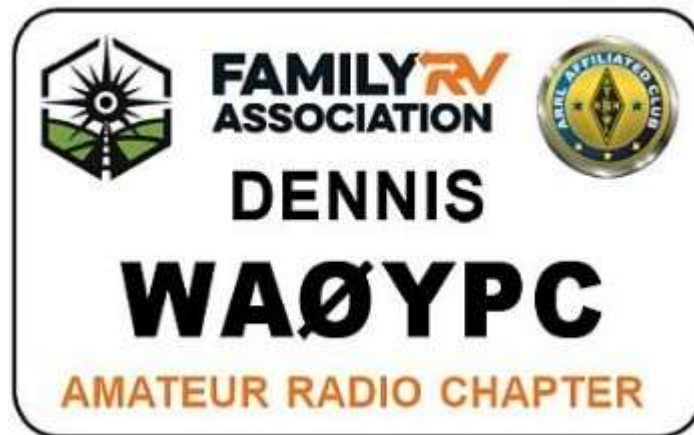

You can order these name badges at the following link:

<https://thesignman.com/clubs/frva-arc.html>

AMATEUR RADIO CHAPTER

**Save the Dates!!
Announcing the 2025 Fall Rally!**



Rally Co-Hosts:

John (WB9FHL) and Jana (N9PBF) Bechtoldt email: bechtjl@gmail.com

Olen (W4EZR) & Margie (KE4YWO) Persons email: ke4ywo@aol.com

When: Sunday, October 5th Check – In
Saturday, October 11th Check – Out

Where: Duck Creek RV Park
2540 John L. Puryear Drive
Paducah, KY 42003

Phone: (270) 415-0404

Website: <https://www.duckcreekrvpark.com/>

The campground is blocking out 15 full hook-up sites.
Our rate is the Good Sam discount of \$50 - \$55 per night.
Additional information will be posted soon on our website:

<http://frvaarc.com>

Try This Crossword Puzzle!

by Chris Codella, W2PA

12/11/2007

Vintage Ham Radio

Across

1. Radio named for a bird
5. Lake ___ swing
9. An SB-220, very broadly speaking
14. Oscar's follower
15. In the middle of EME
16. Tough, durable wood
17. Times past
18. Fine tuning, on some vintage receivers
20. Presses the upper left key
22. They get disqualified in a contest, probably
23. Vibroplex manual item
24. Iowa ham equipment maker, informally
25. Cartoonist Schultz, on CW maybe?
26. ___ generator
28. A step lower in frequency than Re's
29. Proof ender, maybe on CW too
32. Meadow sound
34. Volatile computer storage

35. Four digits of nothing, on CW, for short
36. An R-390 on a carrier?
41. Part of S.R.O.
42. What log entries were often written in, before computers
43. Sixty-one-forty-___
44. Foxhunt (abbr.)
45. Delight
46. Pertaining to a point of connection, in a circuit or network
50. Base predecessor?
51. W2 summer time
53. Dir. beaming Billings from Boise
54. Bad, if a tire...; good, if SWR...
57. Desk Kilowatt maker
59. Lots of Hertz, in the early days
62. ARRL Op-___ (dupe sheets were #6)

63. Receiver maker in HPM's time
64. Walk back and forth
65. Natural antenna support
66. A YL, after getting an X
67. Jet-setters' jets, once
68. Wisdom says that sometimes it's more

Down

1. 20 WPM, 300 Baud, and others
2. SP capital
3. To AMers it's the scratchy one from Heath
4. AMSAT partner
5. Glowing remnant
6. Effect of 5-down on a hot dog
7. Sometimes it's plus sometimes minus
8. AR, on CW

9. Some amplifiers, starting around 1970
10. "Who ___?"
11. Part of EAN, CAN, PAN
12. Future doc's exam
13. Docs of another kind
19. Arrangements or organizations - in databases
21. Like a ruling in HV-land
25. Layer, as with paint
27. Pac. div. ARRL sect.
28. Their dials are greenish-blue
29. Miamisburg, to 28-down
30. Maker of 9-down, once
31. Serial port pin
33. Code proficiency, say
35. Extra stable freq. ref.
36. Kind of logic gate
37. Another kind of logic gate

38. What the original ham band is called today
39. Linear (but not an amp), briefly
40. IN district
45. Honored or favored
47. Covet, as a big antenna farm
48. Collectors' ancestors?
49. Contacts (but not QSOs)
50. ___ King 500
51. VCR button
52. Prescribed amounts
54. Italy, No. Ireland, in prefixes
55. McCartney, Lancelot and others
56. Took a 707
58. Mfgr. of HRO rcvrs
60. Hz, to Hertz
61. A step higher in frequency than so's

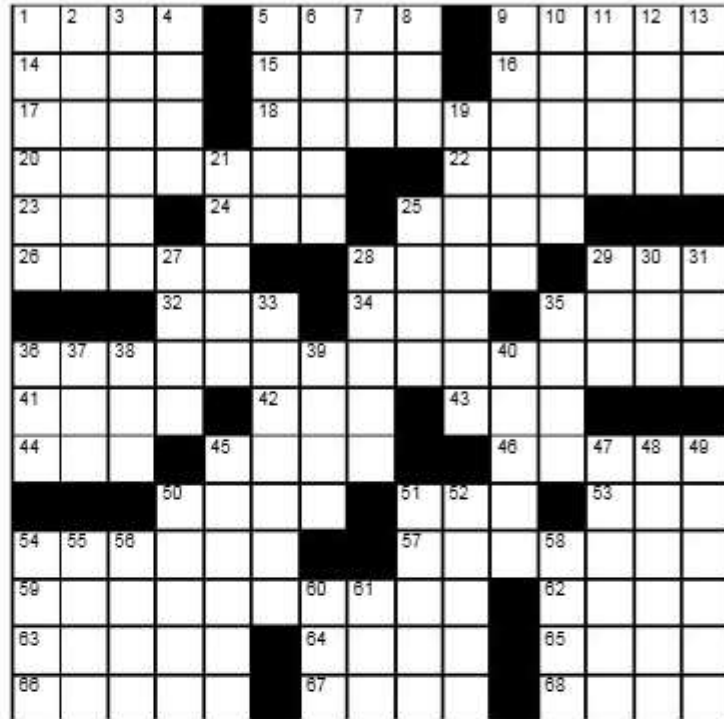

Solution will be posted on website in 2 weeks.

National Director Report 1Q25

George Raney KG5LRB

As the National Director, I represent you to the national leadership in an association called the Governing Board (GB). The GB meets every year at the summer convention; this year at Gillette, WY just prior to the July rally. At the GB, I join approximately 120 other National Directors representing the other chapters of FRVA—we vote on changes of interest that affect every member of the association. This year, elections for National President, VP, Treasurer, and Secretary will be held, as they are every two years. It's rumored that there may be a reorganization in the offing.



At the just completed national rally at Perry GA, I sent out an email to all that highlighted the information provided by National President, Paul Mitchell in his update to the membership. The big picture, national membership is down to 56K persons from approximately 70K last summer. As a result of this continuing contraction, several changes have been made: saving money in the national office and spending writ-large; continued scrutiny of rally expenses, one of the drivers in the association's costs and continuing the roll out of the rebranding effort: the familiar FMCA acronym is now Family RV Association (FRVA). You, too can help. There's a \$10 bounty on new members that comes in the form of a discount on your registration.

INTERNATIONAL AREA (INTO) ELECTIONS - The International Area which ARC falls under, will elect two Vice Presidents and a Treasurer at their Annual Business Meeting which will be held in Gillette in July. If you are invested in running or finding out about duties and responsibilities, you may contact Dick Lowman (President) at: dickl123@aol.com or Lisa Mitchell (Nominating Chair) at 808-351-1458 or lisaalakailua@aol.com.

If you're going to be at the Gillette rally, let me know and we'll get together for breakfast somewhere.

KG5LRB@newmexico.com

George

BLAST FROM THE PAST



BIG OLE TREE, OCHLOCKEE (THOMAVILLE), GA, FALL CAMPOUT, OCTOBER 2011

Secretary Report 1Q25

By Karen Hamilton WB5UFM/Beth Rathke

**FRVAARC SPRING RALLY
GENERAL MEETING, ELKO, GA
March 19, 2025**

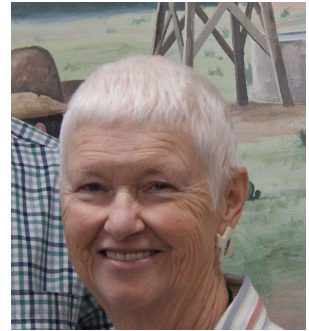

Doug called the meeting to order at 3:05 pm followed by the Pledge of Allegiance.

Officer Reports:

Vice President Dennis Dugan:

Dennis thanked Skip for taking pictures at the rally and Jon Bechtoldt for his work in submitting Larry's name for the Kenneth T. Scott award to be presented in May if accepted.

New name tag ideas were presented for consideration.

Secretary: no report. Motion approved to accept minutes as posted in last Transmitter of January 25th.

Treasurer:

Jana presented proposed budget for the fiscal year. We will keep the 2 domains for use next year until the change to FRVAARC.

Doug thanked Jana for her work in preparing the budget. Motion approved to accept the budget.

National Director:

George explained his function is to attend the annual meeting for the governing board to pass rules for the organization. Two conventions upcoming: Gillette July 16-19, 2025 and Perry, GA March 18-21, 2026. There will be elections for National in Gillette. Information will be on the website. Contact George if you have a preference of vote.

Questions concerning printing of Perry booklet were raised. A comment was suggested that the app be updated as changes occur during the rally instead of printing a large booklet.

The board will attempt to implement tech through Zoom to the entire membership in hybrid form. A motion was made and carried to spend \$159 for the Zoom account.

A discussion followed concerning the increase in dues and membership. Some people do not want to pay the dues, but wish to retain membership in their home chapter. A motion was made and passed that we will follow the by-laws so they will no longer be a member.

George will research insurance liability for guests at rallies.

The executive board passed Technician Training and Licensing classes to be held at Perry in 2026 contingent on logistics.

Doug announced the board approved a Fall 2025 Rally in Paducah, KY and a Spring 2026 Rally following Perry. We are in need of hosts for both of these!

Mike Nabors, VP Intl. Area FMCA and wife Darlene, joined the meeting and were welcomed by Doug.

Doug announced that the club is transitioning away from mailing the Transmitter due to cost. As there was no further business, Doug closed the meeting at 4:00 pm.

Submitted by: Beth Rathke for Karen Hamilton



**FRVAARC Executive Board Meeting, Elko, GA
March 19, 2025**

Doug called the meeting to order at 3:00 pm. All board members present with Beth Rathke as pro tem secretary in Karen's absence. Guests: Hank Blake, Tom Phipps and Tom Abernathy.

Reports:

George- Elections will be held in Gillette. George will attend. FMCA is trying to lower costs and recruit people in an effort to transition to a smaller organization.

Jana- Proposed budget follows this report. There is no budget in place. She will draft a proposed budget to present at the General meeting. Currently we are spending more than we receive. A motion was passed to continue with both Zoom and Jitzi with Dennis' name attached as he will be the next President.

Supporters of FRVAARC are not members, but can make donations.

A motion was made and passed to follow the National By-Laws for membership.

Doug announced that we will continue to have quarterly board meetings.

Perry 2026 will be the location for Tech licenses. The board will work on setting this up.

Doug announced the board suggests a Fall 2026 rally at Paducah and a Spring 2026 rally following the Perry rally.

Meeting adjourned at 3:55 pm.

Submitted by: Beth Rathke for Karen Hamilton



Treasury Report 1st Quarter 2025

ARC FISCAL YEAR BUDGET FOR 1st QUARTER 2025

Jana Bechtoldt N9PB

ACCOUNT	BUDGETED INCOME	ACTUAL INCOME	BUDGETED EXPENSE	ACTUAL EXPENSE
BANK BALANCE	\$10,137.26			
GENERAL	\$ 8,421.08			
RALLY	\$ 1,716.23			
MEMBERSHIP	1515	711.79		
RENEWAL	1365			
NEW	150			
DONATIONS				
SKYMED	150			
HANK FOLK	15	30		
ADMINISTRATIVE COSTS				
CONSUMABLE SUPPLIES (paper, print cartridges, postage, business cards, etc)			150	
COMMUNICATIONS				
IONOS 1&1 VPS Cloud M			150	30
IONOS 1&1 Hi Drive Basic			18	4.5
Echolink			40	
FMCA Domain			17	
FRVA Domain			17	
Zoom			159	
Transmitter	110		450	64.03
RALLY ACCOUNT				
Rally Prizes			1,515	671.32
Fall & Spring Rallies (est. 24 people @ \$90 ea.)			4320	
Rally Equipment (non-consumable - banners, coffee pots, etc)			600	404.97
Rally Supplies (consumable- Chapterfest costs, etc)			300	
Bank Balance 1st Qtr 3/31/25				\$9,704.23



Website Chairperson

by John (Doc) Bechtoldt, WB9FHL/VA7FHL

I had a great time at the Orlando HamCation hamfest. There were several members of our chapter in attendance. Between happy hour snacks, dinner outings, and the usual potluck night, I may have put on a few pounds. That was followed by another great time at our Chapter's Spring Rally, the Twin Oaks RV Park, in Perry Georgia. Again, even more food and happy hour snacks, does it seem that I like to eat? We had some new faces at the Rally and it was nice getting to know them and some we haven't seen for a while.

Our VPS (Virtual Private Server), the Website, EchoLink, and Jitsi servers are running trouble free at the moment. The Website content is going through quite a few changes and certainly looks great. Dennis Dugan has brought in a new look to the site with new updated content on the home page and updated the graphics to reflect the Family RV Association (FRVA) new logos following the transition from FMCA. Thanks Dennis, for all your hard work on the website.

We are looking at alternatives to using Jitsi for video teleconference meetings. We have experienced a few issues when hosting video presentations during the Tech Net and haven't been very successful using the Jitsi recording features. More to come after testing and selection is accomplished.

Our weekly technical video conference on Thursday nights, 8:00 pm ET is well attended and host technical presentations on a variety of subjects along with open forums (if you have anything technical or other topics that you would like to discuss). The link for the video conference is: "<https://meet.jit.si/ARCTechnicalNet>". The link is also on our website "NETS" page in two places. One link under "FMCA-ARC Video Conferences → FMCA-ARC Technical Net" and another one in the Summary area under "Video Tech Net → ARC Tech Net". Just click on one of the links to go to the Technical Net Video Conference.

As a reminder, it is the responsibility of all members to keep their account data up to date. You can edit your account data by going to "MEMBER→Edit Account" (after logging into our website of course) or contact the Membership Chair for help. We have three administrators volunteering to support our VPS. They are:

- Dennis Dugan, WA0YPC
- Doug Borko, NZ2W, and
- John (Doc) Bechtoldt, WB9FHL.

Please direct your problems, questions, and/or comments to any of the administrators. They will determine who needs to work on the issues. As always, if there is any problem that a member is having with our website, please email webmaster@fmcaarc.com about your problem. Hopefully, we can get problems resolved in a timely manner.

EchoLink Report

Attendance/participation at the Tuesday night EchoLink net has seen some resurgence, with between six to nine participants. If you are free on Tuesday's at 8 pm EST join in the roundtable. The EchoLink identifier for our Net is:

FMCA-ARC. There is quite a range of topics discussed, anything from good RV Parks, to boondocking, rallies, sites to see, motorhome/RV issues, health, weather, etc. Come join in on the conversation.



RULES CHAIRPERSON and OFFICER NOMINATION CHAIRPERSON has no report for the first quarter, 2025.

QUARTERLY QUOTE



If at first you don't succeed, destroy all evidence that you tried.

Steven Wright

Membership Report 1Q25



Jana Bechtoldt N9PBF & John Bechtoldt (Doc)

It has been a great start to the New Year here at FMCA (FRVA) Amateur Radio Chapter! Hamcation took place in February and we added 2 new members. However, the FMCA (FRVA) convention in Perry, Georgia yielded the best results! We had a two-chapter event there, the Chapter fair and a Chapter gathering event with snacks in the courtyard followed by fireworks! We talked to several hams who were interested in joining, inactive hams wishing to become more active and non-hams studying for their ham license. So far, we added 6 new members as a result. Plus, we continue to receive renewal applications from previous members!

Special thanks to current members Dennis and Janet Dugan, Dave and Beth Rathke, George and Pam Raney, Delores and Fred Murph, Calvin Means, Jana and John Bechtoldt for helping at the Chapter events in Perry to welcome and recruit new members!

Welcome to our new members:

Joe (KD4QN) and Jewel Symmes from Elberta, AL

Jerry (N4OMF) Segers from Kingston, GA

Wayne (KF7FWK) and Betty Cernie from Lake Havasu City, AZ

Kenny (KT4X) and Carol (N4OKO) Trussel from Davisboro, GA

Steve (K4NU) and Gina Waterhouse from The Villages, FL

James (N7SVC) and Roberta Hall from Selah, Washington

Cary (K5DZR) Camden from Austin, TX

Jon (K8JFG) and Kay Gray from Howard, Ohio

The FRVA ARC Rally in Paducah, Kentucky has been announced for the first full week of October. Come and join in the fun and meet your fellow Hams in person!

MEMBER CONTRIBUTION

“Pam and David Wooten’s (W5DSW) trip to Nova Scotia and Newfoundland Canada 2024”.

Pam and I wanted to take a trip to a different place than most people visit. At the time, I was reading a biography on Guglielmo Marconi and was intrigued by many of the places he tested his “Spark Gap Transmitter and Long Wire Antennas. So, after some research on the internet and speaking with Doctor Bob Lewis N8GU and reading about his trip to eastern Canada, I decided I would pitch the idea to Pam...first impression was well...sounds a bit boring and ham radio ish. With a little coaxing she finally said: ‘what the heck, I’m the boss and I can work anywhere along the way if there is cell service “. So here we go.

I began working on the itinerary. We had a fixed amount of time of 21 days. So early on we decided, that driving the motorhome from Texas to northeastern Canada was not feasible. So, with no motorhome or tow we decided we would fly to Halifax Nova Scotia, rent a 4-wheel drive SUV and Halifax would be our starting and ending point. We made 14 hotel reservations and booked our ferry rides.

At 2:30AM September 05, UBER picked us up here in Benbrook Texas then on to DFW airport; a few hours later we were in New York. The early morning flight into LaGuardia was breath taking. After a short layover we arrived in Halifax, rent a Jeep Grand Wagoneer and head to the hotel. I then installed a Yaesu HT8800 VHF/UHF Dual Band Radio in the Jeep with a MFJ mag mount antenna on the roof, drove down to the “Waterfront” in Halifax and Dartmouth. Here I made a couple of contacts on local 2-meter repeaters and used the “Repeater Phone App” to find what repeaters were close. Every evening, I checked into the “Newfoundland and Labrador Link Repeater System” using ALLSTAR 43085. A nice bunch of hams provided some good places to visit while on the trip.

The next couple of days we visited the following sites in Halifax; the Citadel near Dartmouth, the Halifax Explosion Site (Dec. 01, 1917), the Titanic Cemetery at the Fairview Cemetery and the Atlantic Marine Museum, they had an amateur radio station in the museum (VA1MMA), unfortunately no one was around to let us take a close look at it. The next day we started driving north to Sydney to board the ferry. After checking in at the hotel, we drove over to Glace Bay to visit the Marconi Site and Museum. This was Marconi’s second transmitting station. The museum was closed since it was Sunday, so I took some pictures, and we went to supper.

Monday at 12:30pm, we boarded a 650’ long ferry named “MS Highlander” for a 7-hour ride to Port Aux Basques, NL (Newfoundland). It was a very nice trip, beautiful weather and calm seas, we arrived without incident.

On Tuesday we left Port Aux Basques, enroute to the City of Cow Head on the west shore of Newfoundland. We drove through Gros Morne National Park; the park is approximately 697 square miles. While in Cow Head, I set up the Yaesu 991a with the Buddipole horizontal and made a few 20-meter contacts back to the US using the Rig Expert AA-230 Zoom for tuning.

We left Cow Head after a couple days and continued our drive north to St. Anthony, NL. While driving up the coast we visited the site of the USS Ethie which was thrown into the rock cliffs during a huge winter storm in 1919. All the passengers and crew made it safely with the help of residents. Even a 2-year-old baby was hoisted from the ship to shore in a mail bag attached to a rope. Google “S.S. Ethie” for the full story.

While in St. Anthony, we drove to Quirpon; it is the most northerly point in Newfoundland. Quirpon is near the historical site L’ Anse aux Meadows. L’ Anse aux Meadows is an archaeological site first excavated in the 1960’s of a Norse settlement dating back approximately 1,000 years. The weather was cold and rainy, but we did work in a tour. While exploring and talking to the locals, we found out that there were numerous NORAD radar installations placed along the 50th parallel which was called the “Pine Tree Line”. These installations were strategic radar sites used to monitor inbound aircraft. One of these installations was installed in St. Anthony and manned by Americans and Canadians. It was deactivated in 1991.

After leaving St. Anthony we had to backtrack some. We drove back through the Gros Morne National Park headed for Deer Lake. Deer Lake is still considered part of the western coast but a little further east. The town is more modern and not so affected by the coastal seasons. We found a nice park to do some HF work, maybe some POTA and it had a nice gazebo with plenty of open space. While setting up, a fellow ham drove by and asked if I needed some help. I said sure; he and I operated for 2 + hours. His name was Art Sturgis VO1AJD; what a nice man; everyone was so friendly. We didn't make many contacts, but we had some good pizza in town. The next day we drove to Twillingate for another look at the North Atlantic. While in Deer Lake we visited the North Atlantic Aviation Museum, which had some displays about how the four coordinated attacks on September 11 (commonly known as 9/11), effected this small island in Canada.

The next day we left Deer Lake for Gander, which is in the central region of Newfoundland. Gander is where 38 airplanes were diverted during 9/11. One additional fact is that 242 aircraft safely landed in Canada when air space was closed in the US, during the 9/11 attacks. There is a lot of history here in Gander. It was a stopping point for early international flights, needing to top off their tanks.

The next stop, St. John's, NL the most modern town in Newfoundland. We spent a couple of days taking tours and sightseeing. Our hotel room overlooked the port, I'm glad I brought a HT marine radio and binoculars. Probably the highlight of the trip was visiting Signal Hill/Cabot Tower, which was where Marconi made some of his Trans-Atlantic contacts. While planning for the trip, I reached out to SONRA, the local radio club that operates the station and asked permission to operate at their station VO1AA. Chris Vernon VO1CH made the arrangements for me to visit. I met Bob Evans V1RE on the second floor and made a few contacts on 15 meters to Alabama, Germany, and New York. As we were operating the station, several visitors who were touring Signal Hill would walk by and ask what we were doing; we would give them a quick talk about amateur radio. Overall, it was a great experience, despite the torrential rain.

Well, that's about it. We are heading back west to catch the ferry in Argentia, NL. On the way we stopped near Placentia Bay where Roosevelt and Churchill signed the Atlantic Charter. The document was signed aboard the USS Augusta. The second stop was Castle Hill, a French Settlement from the 1600's. We boarded the ferry MS Ala'suinu (666' long) for a 16-hour ride back to North Sydney. On this leg we got a cabin. We arrived on time in North Sydney, filled up the Jeep and headed back to Halifax.

The next morning, we dropped off the Jeep and headed to the airport. Our flight was late leaving Halifax, so we missed our connection in Philadelphia. There was a later flight to DFW which got us home at 12:30am.

All in all, we had a great 19-day adventure! We drove on the Trans Canadian Highway, Provincial Roads, Toll Roads, and Unpaved Roads. Along the way we met some wonderful people.

73's David W5DSW

Here are a few links for more information:

<http://www.7163net.com/Marconi-Aug-2021.pdf>

[Ala'suinu | Marine Atlantic](#)

[Marconi National Historic Site](#)

[The Wreck of the S. S. Ethie](#)

[nl hamradio](#)

[Lieu historique national de L'Anse aux Meadows](#)

[Gros Morne National Park](#)

[Pinetree Line - Wikipedia](#)

[Maritime Museum of the Atlantic |](#)

[North Atlantic Aviation Museum | Gander](#)

[Halifax Explosion - Wikipedia](#)

[Atlantic Charter - Wikipedia](#)

[Halifax Citadel National Historic Site](#)

[Castle Hill National Historic Site](#)

[MV Highlanders Ferry - Vessel Information | Marine Atlantic](#)



Hamin' in Newfoundland



Glacier Bay



Art Sturgis VO1AID & Dave Wooten W5DSW
hammin' at Deer Lake



Flag of Newfoundland



Dave setting up at Cowhead

Submitted by Dave Wooten W5DSW

Portable Battery Charger

By Dave Wooten W5DSW

Here is project, I did a while back. It's a portable battery charger with different types of connections. The box is a favorite of the grand kids with all their phones, tablets, RC cars, drones and all their other devices. It also works for ham radio.

Bill of Materials:

- Hard Case from Harbor Freight
- Eco-Worthy LiFePO4 Battery 12.8V 20Ah
- Eco-Worthy Smart Battery Charger
- Battery Charger Receptacle with on/off switch
- 4 Window DC Power Meter
- 2 Strobe Lights with multi-mode switch
- PV Connection
- Power Outlet
- 4 USB-A
- 4 USB-C
- 2 30A Power Pole Connections
- 300W Power Inverter
- Assortments of adaptors and cables
- Fused, with a main on/off switch



'73 David W5DSW



MEMBER CONTRIBUTION

EASY IMPLEMENTATION OF AN SDRPLAY PANADAPTER

By Bob Blackstock WB5MRG



Several years ago, I submitted a Transmitter article on SDR based panadapter for a Yaesu FT991. It featured a general description of a panadapter display and its functions. This article will be on the actual implementation of a SDRplay radio panadapter for an ICOM IC7300. The article will also apply to most modern-day HF radios. The main reason behind this article was because of the much easier implementation of the project. It no longer required the use of virtual comports and setups were greatly improved. The freeware program used for the simplification was the "OmniRig" by Afreet Software Inc. It turns out the SDRplay SDRUno software was written to directly support the OmniRig package.

Of course, other reasons for a SDR panadapter for the ICOM IC7300 were the same as the first article stated. Most modern-day HF radios feature a panadapter within its LCD display. For me, the five to seven-inch LCD display falls way short of the high end SDR radios PC monitors. It's not only the display size, but the functionality capabilities.

Figure one depicts the basic block diagram of my IC7300 panadapter project. The original FT991 project has the same diagram. The difference is the interface software connecting the SDR radio to the IC7300. The interface software has to handle Kenwood TS480 commands for the SDR radio and in this case, ICOM commands for the IC7300. It is important that the units are in frequency sync.

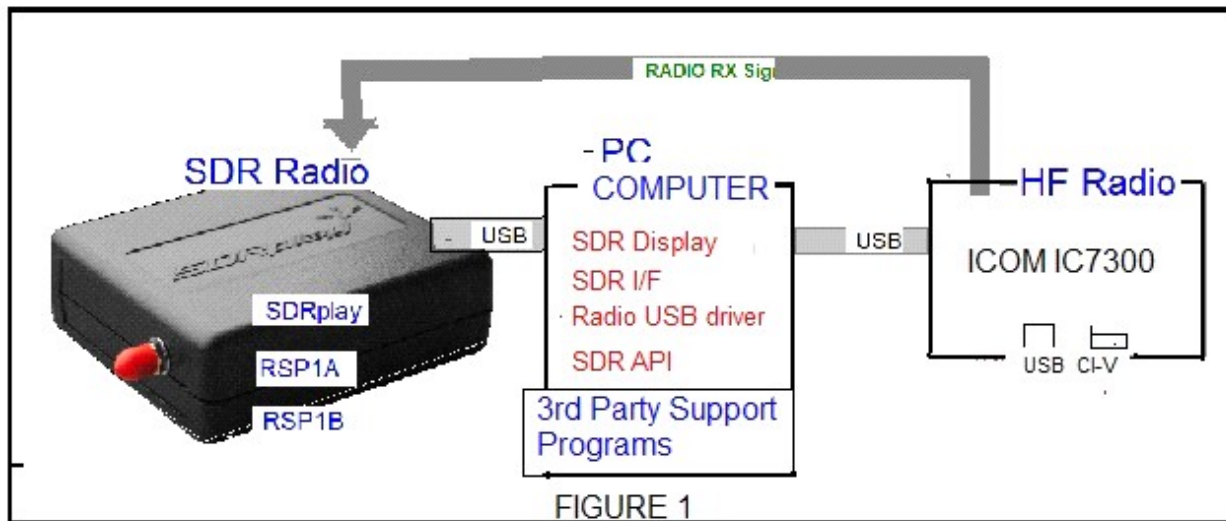

Software requirements may appear to be complex and difficult to install. All the software requirements are freeware and provide an easy install. Most third parties (digital etc.) are also freeware. Below is a list of the software programs.

- SDRplay radio Display Software Program
- Radio USB driver -required for the radios USB comport
- SDRplay Radios API -SDRplay API-V3.15
- SDR & HF Radio interface -OmniRig
- Third party support programs. RTTY, SSTV, Digital HF, etc.

Figure two depicts a detailed overview of the project software. The OmniRig program acts as a go between for the IC7300 and the SDRuno program. The two units are in sync and any frequency change by one is reflected in the other. My third-party program, MRG, is in sync with the radio itself. The MRG program consists of a series of dedicated frequencies such as major nets, etc. One does not have to look up frequencies and turn the tuning knob.

Because the IC7300 only supports two comports, only one third party program can run as shown. Besides my MRG program, I did use ICOMs RS-BA1 and JS8CALL.

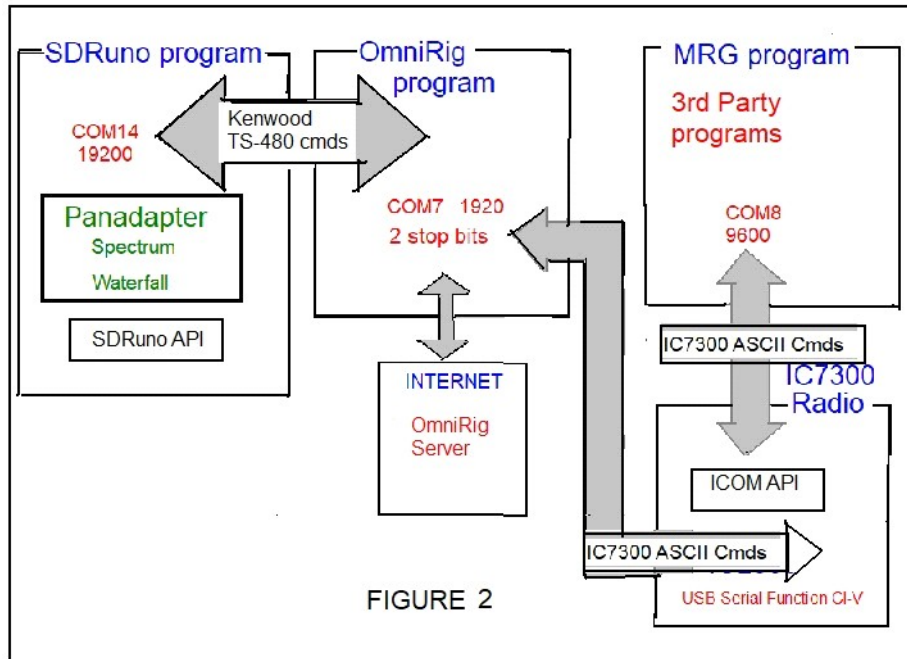

Other than any third-party support programs, only the OmniRig and SDRuno require any setups. You may not even use any third-party programs; the panadapter and radio operations exist without them. The ease of setups for the OmniRig and SDRuno are the primary reason for this project.

OmniRig is a freeware program provided by Afreet Software which was the key to making this project. It was written to support a large number of rigs and third-party software. Because the SDRuno program was written to support it directly, the installation was much easier. Much of the setup is hidden from the installer. Mainly, it required no virtual comports and the problems that go with them.

Figure 3 below is a drawing showing the simple setup of the OmniRig program. It comes up after the initial installation and normally does not require any action after that. The setup menu is the only display of the OmniRig program and will not appear again unless executed. The program will run in the background only when the SDRuno program is being executed. It will remain active after the PC is turned off. You can run it again by going to apps and click on icon.

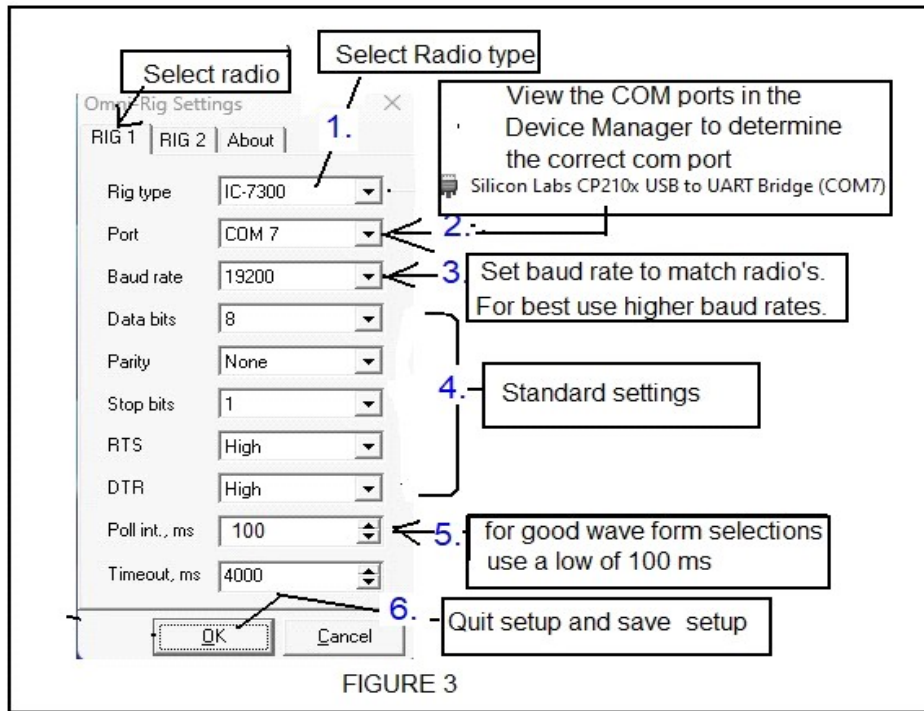

Again because of the SDRuno software direct support of the OmniRig program, interface is very simple and hidden from the user. One can check for the proper interface connections by viewing the main panel's setting ORIG tab. Figure four shows the OmniRig connections with the SDRuno. The bottom display line shows connection to the OmniRig internet server. Verification showed that no internet connection was required for SDR operations. The OmniRig supports a huge number of radio types. The list can be found in the OmniRig file "c:/program files (x86) /Afreed/OmniRig/Rigs".

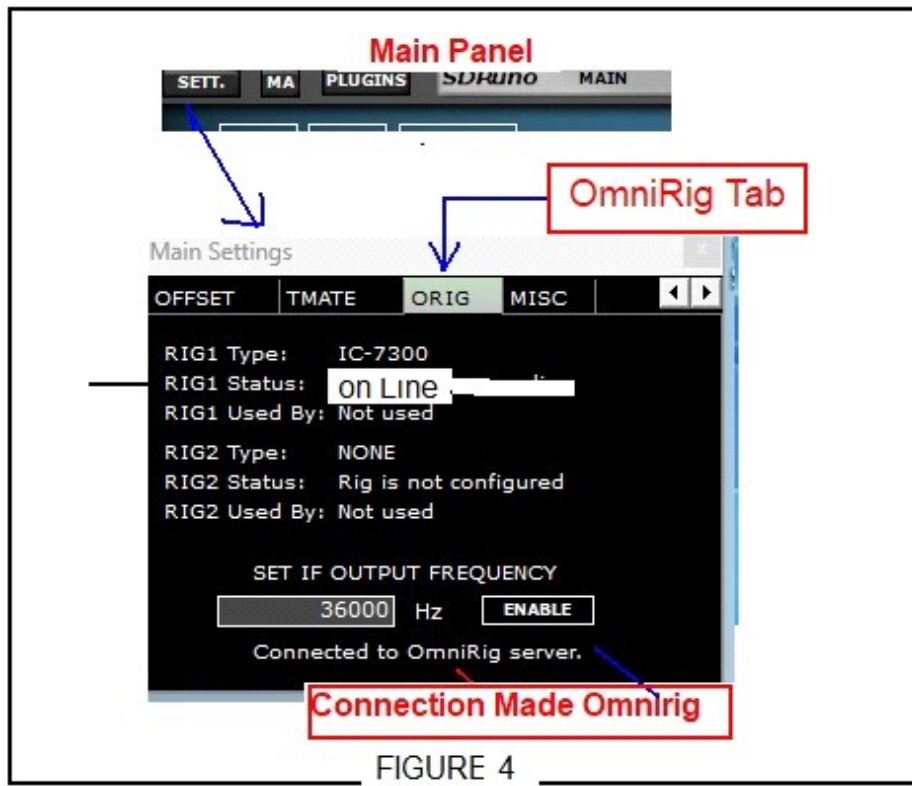

The other settings are shown in Figure 4 are the radio type and status. Only one rig is used as shown in the figure. The tab "ORIG" does stand for OmniRig settings. Figure 5 shows the Rx Control Panel settings depicting rig selection. One must ensure the correct rig is selected and the sync tab is on. Note at program start it may be necessary to select the RSYN1 tab on/off to start sync

As for as the SDRuno program, no setup or operation will be presented here. The SDRuno is a powerful panadapter that does have a learning curve associated with it. A detailed operation manual is available from SDRplay. My original article did cover a number of the basic features.

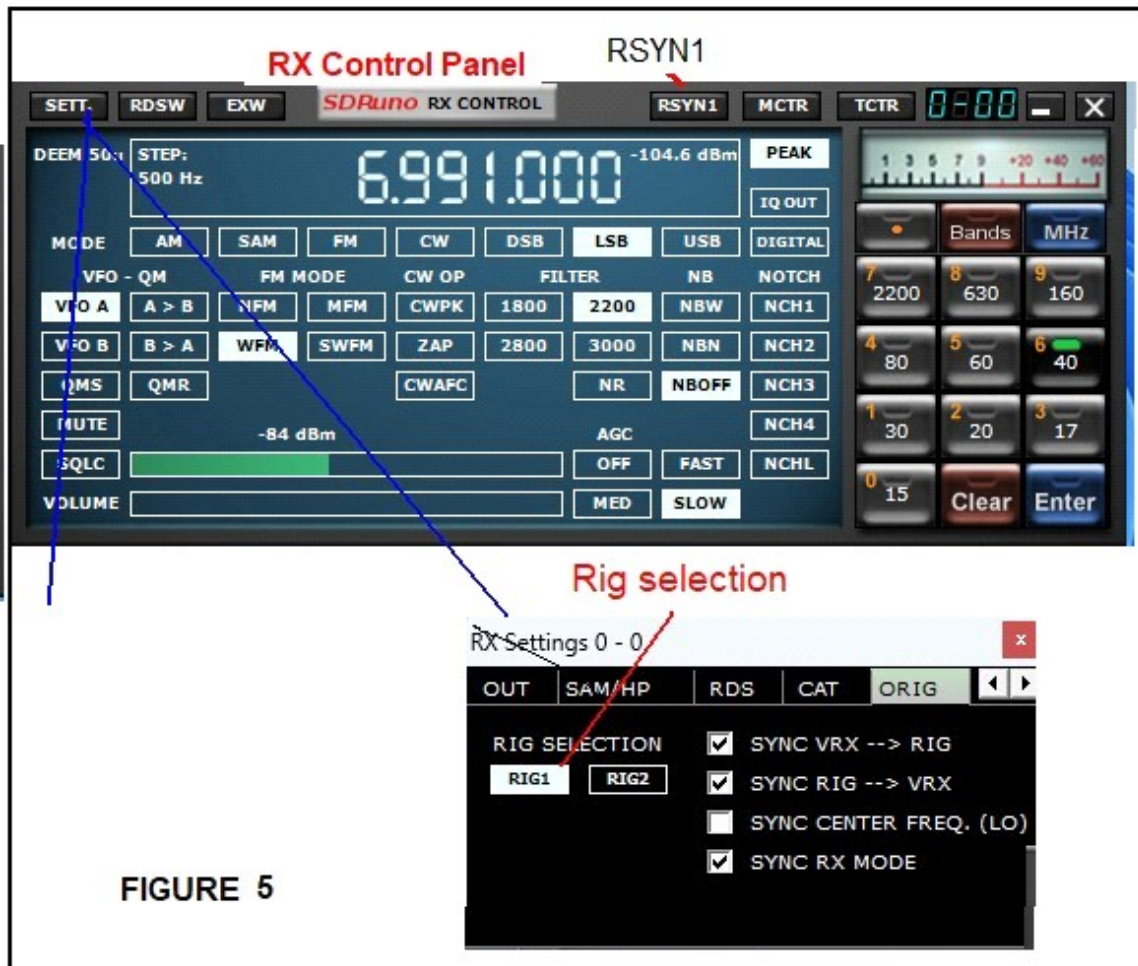
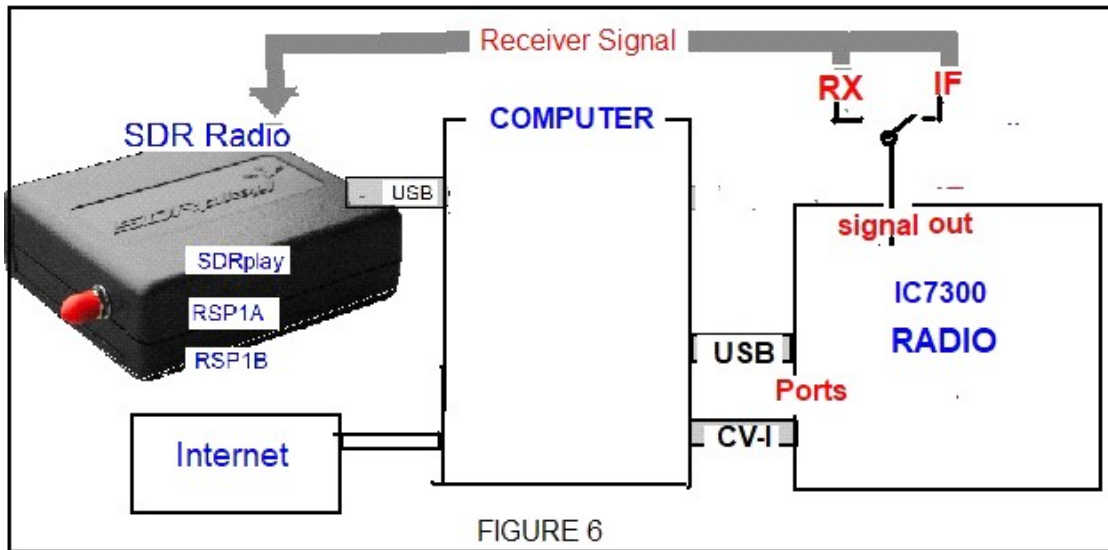

FIGURE 5

Figure six defines the basic hardware required for the project. The SDR radio used here was the SDRplay RSP1A. The RSP1A is discontinued with the RSP1B being the replacement. There are a huge number of other low cost SDR radios available. The SDRuno program used here may not work with all others. SDRplay has a very good web page with information and support.



The computer required could be any modern-day lap top or desk top. I have run the programs on seven, ten and eleven.

The radio used for my project was the ICOM IC7300. Most any modern-day radio could be used. As stated earlier, a detailed list can be found on the initialization file. Here, two radio ports were used. The CV1 port was used by my third-party program and the USB port used by the OmniRig program. The ICOM7300 does not have any hardware support for a panadapter signal. One choice would be a T/R switch such as MFJ1708 providing a RF signal to the SDR radio. Another choice would be a low-cost cable modification that would result in an IF signal output. My choice was a PTRX electronic buffered RF RX signal output. Either method will work, but the RF can provide an improved band width signal.

The project provided me with a very easy implementation of a higher end panadapter for my ICOM7300. I'm still working on the finer points of using the SDRuno software and possible third-party support.

Thanks to Lana J. for her typing and grammar corrections. Also, thanks to fellow hams for reviewing the article. Any email comments would be appreciated - good or bad.

73's WB5MRG wb5mrg@att.net

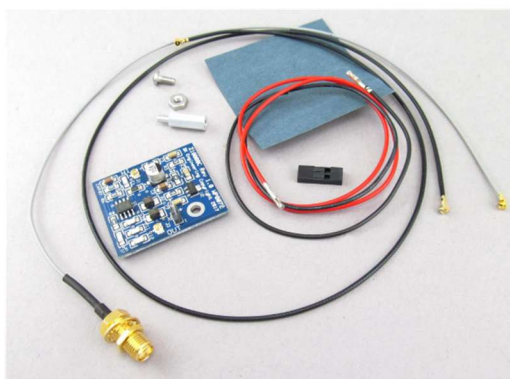

WONDERLUST DREAMS

LJRB

Winter is over and it's none too soon;
Springtime is here and we're over the moon!
What's our first move, where shall we go?
Somewhere new or somewhere we know?
Will it be far away or somewhere near?
Everywhere is lovely this time of year.

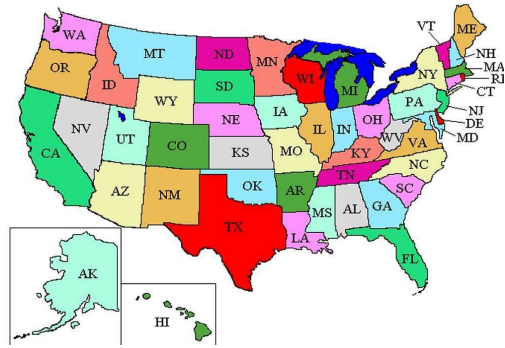

The camper is ready and so are we,
Throw a dart on the map and let's just see,
Could it be Florida or maybe Idaho?
How about Texas or New Mexico?
We love the Carolinas, Louisiana and Arizona;
Making up our minds is certainly gonna
Be a hard decision to finally make.
Wherever we choose won't be a mistake.



Alabama, Georgia, Oklahoma and Kentucky,
The Virginias, the Dakotas, and aren't we lucky?
So many places from which to choose,
Wherever we decide, we really can't lose.
We should sleep on it though, as decisions and schemes
Sometime come to us in our deep purple dreams.





WE4RV

AMATEUR RADIO CHAPTER

Registration for the 2025 Fall Rally!



Duck Creek RV Park
2540 John L. Puryear Drive
Paducah, KY 42003
Phone:(270) 415-0404

Make Your Camp Site Reservations SOON. 15 sites are on hold.

Tell them you are with the **FRVA ARC RALLY** to get the **Discount!!**

Site Rate is \$50 - \$55 after the Good Sam Discount.

When: Sunday, October 5th thru Friday, October 10th, 2025 (check out October 11th)

Rally Co-Hosts:

John (WB9FHL) and Jana (N9PBF) Bechtoldt - email: bechtjl@gmail.com
Olen (W4EZR) & Margie (KE4YWO) Persons - email: ke4ywo@aol.com

TALK-IN FREQUENCY: 146.55 MHz

Guests are welcome to attend our Rally by completing the registration form. Only ARC Members are eligible to vote during the General Business Meeting in accordance to FRVA ARC By-Laws and Standing Rules. Only ARC Members are eligible for Chapter-sponsored door prizes.

RALLY OFFICIALLY BEGINS AT 4:00 PM ON Sunday, October 5th

Join us in the Clubhouse for happy hour followed by a welcome dinner.

Appetizers to share are Welcomed. Bring Your Own Beverage (BYOB)

Stay tuned for more info on the fun activities and meals planned for the rally!

----- Clip Here ----- Retain upper portion for reference ----- Clip Here -----

Mail this Registration with a check for Rally Fee by September 15th, 2025 or email this form to bechtjl@gmail.com and pay via the QR code below.

Mail to: Jana Bechtoldt
1418 South Yale Drive
O'Fallon, IL 62269

Name(s): _____

Amateur Radio Call(s): _____ / _____ FRVA#: _____

in Party: _____ x \$90 = \$ _____ (make check payable to Jana Bechtoldt)

